

Despooling set DU-300

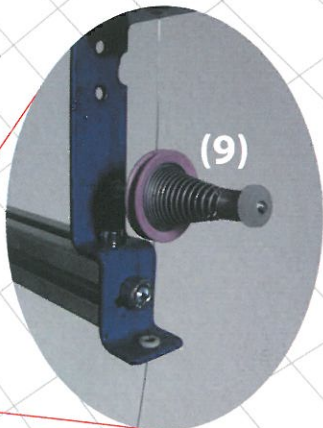
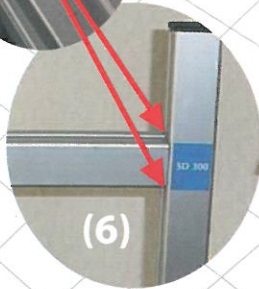
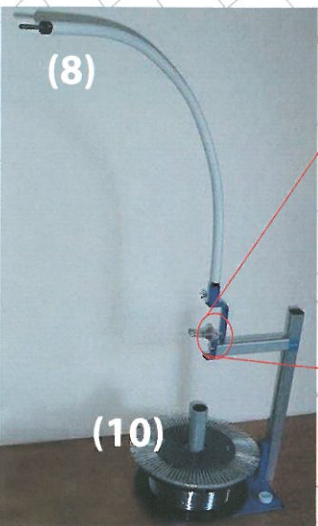
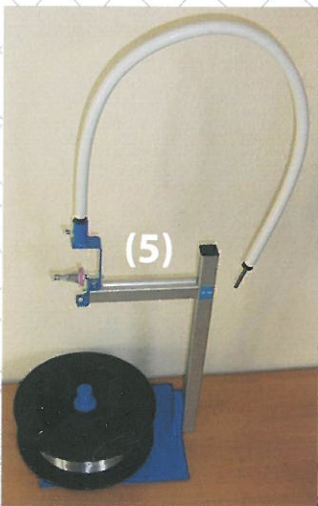
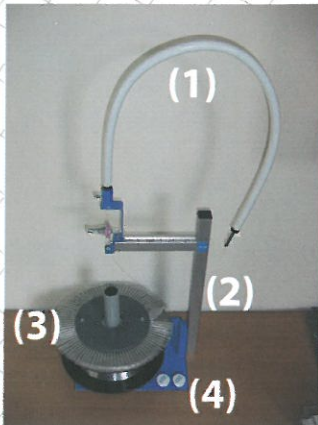

- Easy and simple to setup
- Evenly tensioned wire
- Smooth wire take off and guidance to the machine adapter

The set contains a wire guiding tube (1), a base unit (2), a brush cap assembly (3), two magnets (4), and an allen wrench.

- Position the tension adjustment arm (5) as shown on the base unit mark. For the adjustment use an allen wrench 3mm. The screws are at the corner of the arm (6).
- Fasten the wire guiding tube to the bracket and tighten the thumb screw.
- Place spool on base unit with the label as well as wire attachment facing upwards. Use the magnet (7) to hold the wire at the spool during set up.
- Adjust the wire guiding tube with an angle of min. 90° (8) without kinks with the tip towards the stitcher.
- Feed the wire through the bottom eyelet, between the ceramic discs (9) and through the upper eyelet into the wire guiding tube until wire appears at the tip of the tube.
- Place brush cap on top of spool (10).
- Remove the magnet and feed the wire into your stitcher

Note:
Raising or lowering the tension adjustment arm decreases or increases the tension of the stitching wire.